



CONOTEC

Digital Temperature Controller

CONOTEC CO., LTD.

www.conotec.co.kr

Instruction Manual CNT-P600



- * PID temperature controller
- * Two relay output
- * Two output used as electric current /SSR (Cycle / Phase control / General On/Off)
- * Alarm output with the hardware select function / Current transmission / The user can select control output
- * Resistance temperature detector Thermocouple, NTC Sensor, Voltage (mV, Volt), Current (4-20mA) and other variety of sensor input
- * Supports RS485 Communication (MOD BUS - RTU)

※ Thank you for purchasing this Product of Conotec.

This Manual contains useful information for your proper use of the Product and for prevention of damage and breakdown of the Product which may be experienced by users' carelessness. Please keep this Manual handy for future reference during the service life of the Product.

Regarding the English - language manual, please download it our web-site.

1 Safety Precaution

Please read all precautionary information before use, to ensure proper usage.

※ The specification and external dimensions etc of the Product contained in this Manual can be changed without prior notice for further improvement in the product performance.

Warning

1. This Product is not designed to be used as a safety device. Please add a secondary safety device if this Product is used as a controller for a device that has the potential of causing personal injury, damage to the surrounding machine or damage to other properties.
2. Do not perform any wiring, maintenance or repair work while the Product is connected to power.
3. Check the terminal number before connecting to power.
4. Do not disassemble, process, improve or repair the Product.

Caution

1. Please read and observe safety warnings and cautions as well as the method of operation before installation, and use the Product within the scope of specified and permitted usage.
2. Do not wire or install the Product on a motor or a solenoid having a high level of inductive load.
3. If the sensor of the Product needs to be extended, make sure to use the same cable as the original. The length of cable should be kept at a minimum.
4. Do not use a part that may generate arc when it is open or closed near or on the same power supply.
5. Keep the power cable away from a high voltage wire. Install the Product away from water, oil and excessive dust.
6. Install the Product away from direct sunlight and rain.
7. Install the Product away from strong magnetic force, noise, vibration and impact.
8. Keep the Product away from a place exposed to strong alkaline or acid materials.
9. Do not splash water directly onto the Product to clean in case the Product is installed in the kitchen.
10. Do not install the Product in a place exposed to high temperature/humidity.
11. Use the sensor cable with care not to allow cut or scratch.
12. Keep the sensor cable away from a signal cable, power cable, power and load cable. Use a separate cable pipe.
13. Please note that no after-sales service will be available if the Product is disassembled or altered without permission.
14. Please observe the hazard and precautionary statements shown on the terminal wiring diagram.
15. Do not use the Product near a device generating a significant level of high frequency (such as high frequency welding machine, high frequency sewing machine, high frequency radio, high capacity SCR controller etc).
16. Use of the Product in violation of the manufacturer's instructions may cause personal injury or physical damage.
17. Keep the Product away from the reach of children as this is not a toy.
18. The Product must be installed by a qualified technician only.
19. The Company will not be held responsible for any damage caused by non observance of the above instructions or the user's negligence.

Hazard

Hazard related to electric shock

1. Electric shock – Do not touch the AC terminal while current is flowing. It may cause electric shock.
2. Disconnect the input power before checking the input power.

2 Product Specification

| | | | | | | |
|---------------------------|--|--|--|----------------|---------------------------|----------------|
| Input Power | 100~240VAC 50/60Hz | Display Accuracy | ±1% rdg ±1digit | | | |
| Display Method | 7segment 0.51Inch 4Digit 2Line | | | | | |
| Output Spec. | OUT1 : Current output and transmission / SSR output (general, cycle, phase control) - Current : Within resistive load 500 ohm, SSR: Within 11VDC ± 2V 20mA | | | | | |
| | OUT2 : Current output and transmission / SSR output (general, cycle, phase control) - Current : Within resistive load 500 ohm, SSR: Within 11VDC ± 2V 20mA | | | | | |
| Sensor Spec. | AL1 or OUT3 : 1c 250VAC 2A Relay | | | | | |
| | AL2 or OUT4 : 1a 250VAC 2A Relay | | | | | |
| Communication Spec. | Type | Sensor Name & range | Type | | | |
| | RTD | DPT100 | -199.9 ~ 400.0°C | Thermistor | | |
| | | JPT100 | -199.9 ~ 400.0°C | | NTC10K(LT) -55.0 ~ 99.9°C | |
| | TC | K | -50 ~ 1200°C | Voltage | | |
| | | N | -50 ~ 1200°C | | mV | |
| | | T | -50 ~ 400°C | | 0~5V | 0.0 ~ 5.00V |
| | | J | -50 ~ 1200°C | | 1~5V | 1.00 ~ 5.00V |
| | | E | -50 ~ 1000°C | | 0~10V | 0.00 ~ 10.00V |
| | | | | | 0~20mA | 0.00 ~ 20.00mA |
| | | | 4~20mA | 4.00 ~ 20.00mA | | |
| Ambient | 0~55°C, 35~80%Rh (to be free of freezing or condensation) | | | | | |
| Permitted voltage | 90~110% of the supply voltage | | | | | |
| Output Selection | Type | Selectable Hardware | Selectable Output Format | | | |
| | Control Output 1 (Heating Control) | OUT1, OUT2 | SSR On/Off, SSR General PID, SSR Cycle PID, SSR Phase PID Current PID | | | |
| | | OUT3, OUT4 | Relay On/Off, Relay PID | | | |
| | Control Output 1 (Cooling Control) | OUT1, OUT2 | SSR On/Off, SSR General PID, SSR Cycle PID, SSR Phase PID Current PID | | | |
| | | OUT3, OUT4 | Relay On/Off, Relay PID | | | |
| | Alarm Output 1 | OUT3, OUT4 | High temperature alarm, low temperature alarm, high-low temperature alarm | | | |
| | Alarm Output 2 | OUT3, OUT4 | Sensor error, roof error (output error) | | | |
| | Transmission Output 1 | OUT1, OUT2 | Current temperature transmission, set temperature transmission, Controlled variable transmission | | | |
| Transmission Output 2 | OUT1, OUT2 | Current temperature transmission, set temperature transmission, Controlled variable transmission | | | | |
| Digital Input | Input 1, 2, 3 | | | | | |
| Power Outage Compensation | Approx. 10 years (Non-volatile semiconductor memory type) | | | | | |

Caution

* To enable the cycle PID control and phase PID control with SSR, SSR must be of the Non zero-crossing type and its reaction speed must be within 1ms.

3 Front Operation & Display

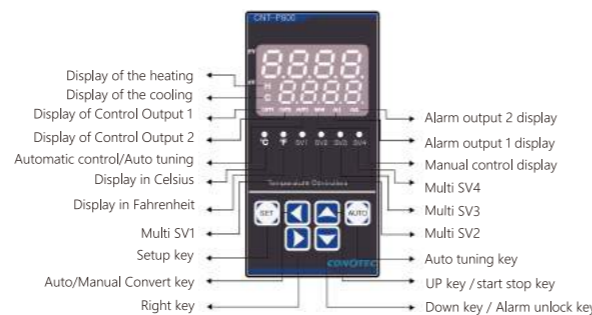

Display of Special Function

OUT1, OUT2(Display of control output) Flickers depending on the size of controlled variable for PID control.

AUTO(Auto Control/ Auto Tuning) Switches on in the automatic control mode. Flickers during auto tuning.

SV1,SV2,SV3,SV4(Multi SV) Displayed depending on the set temperature selected by the external digital input key.

Initialize Press and hold the left and the right keys for 3 seconds to initialize all setup values.

Auto/Manual Switched to the Auto or the Manual mode when pressed on the Operation Screen. **AUTO** for the automatic mode; **MAN** for the manual mode.

Start/Stop Switched to the Start or the Stop mode when pressed on the Operation Screen. **Stop** indicating the stop mode

Release Alarm The alarm output is released during an alarm event when pressed on the operation screen.

Auto Tuning The automatic tuning starts or stops when pressed on the operation screen.

Caution: The Select Auto/Man, Start/Stop, Release Alarm and Auto Tuning functions etc can be operated by the external digital input function. Once they are set to be enabled by an external input, the keys on the controller are disabled.

4 External Dimensions and Panel Processing Size

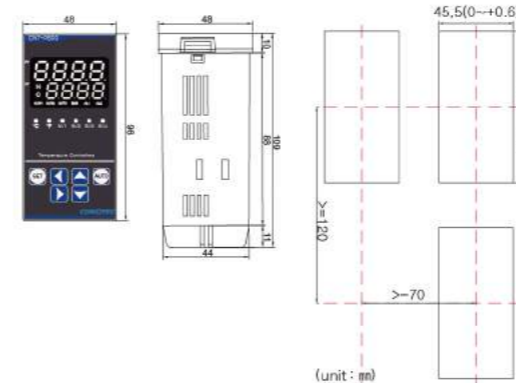

5 Terminal Wiring Diagram

Method of Switch Use depending on the Digital Switch Function Setup

| | | |
|--|-----------------------|--|
| If set to the Start/Stop function | Use the Select switch | |
| If set to the Release Alarm function | Use the Push switch | |
| If set to Select Auto/Manual Mode function | Use the Select switch | |
| If set to the Auto Tuning function | Use the Push switch | |
| If set to the Multi SV function | Use the Select switch | |

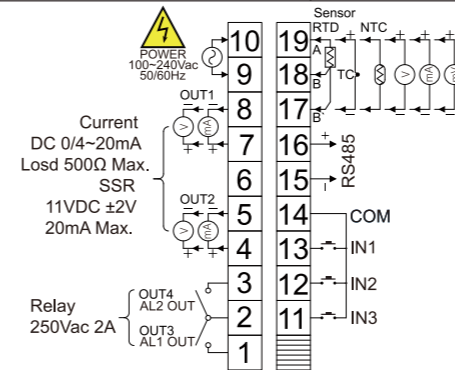

Caution
* Turn power OFF before wiring or replacement.
* The relay connection capacity is 250VAC 2A at a maximum. Use of the load in excess of the relay capacity may cause fusion of the relay contract, poor connection and damage to the relay.

Warning
* To enable the cycle PID control and phase PID control with SSR, SSR must be of the **Non zero-crossing** type and its **reaction speed** must be within 1ms.

6 Logo shown upon Power-on



Caution
If the logo is displayed repeatedly upon power-on, it is probable that the input power is incorrect. If not, please contact the Company.

Warning
Unstable power supply may cause damage to the internal memory.

7 Program Setup

Change of Set Temp. and Manual Controlled Variable

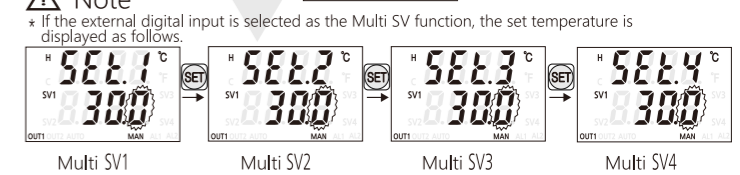
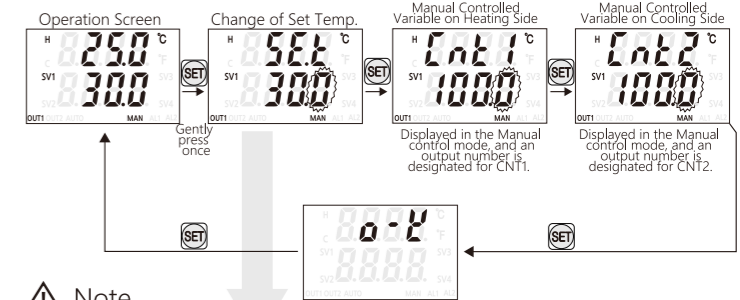

* If the Multi SV function is not selected, only the SV1 setup is displayed as same as the screen under "Change of Set Temp." as above.

Change of Auto or Manual Control

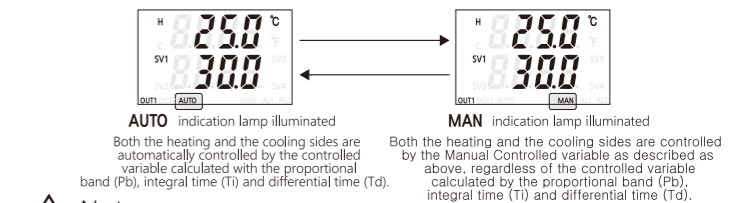

Caution
* If the external digital input function is set to "AUTO/MANUAL control", the front key operation will be disabled.

Start and Stop of Auto Tuning

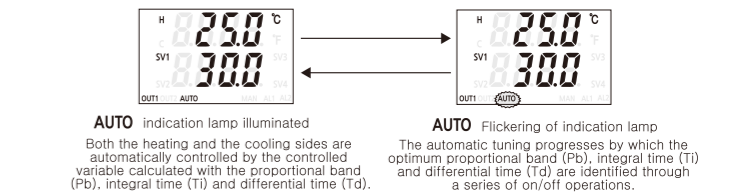

Caution
* If the external digital input function is set to "Start/Stop Auto Tuning" the front key operation will be disabled. Some menus cannot be changed during auto tuning. The word **Err** will be displayed for a short period of time to indicate that tuning is in progress.

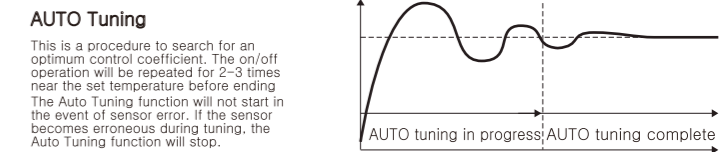

Initialization

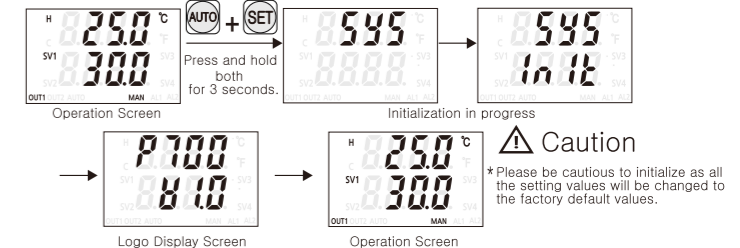

Error Display

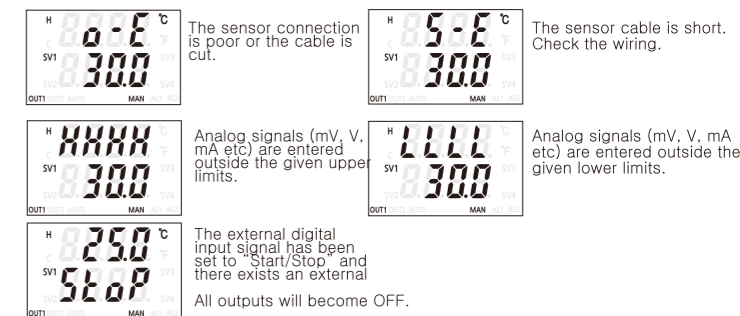

Setup - Heating Side (Control Output 1)

Selection of Output Hardware for Heating Side (Control Output 1)

Current or SSR output

out1, out2, out3, out4

Selection of Control Method for Heating Side (Control Output 1)

SSR ON/OFF Control Enabled when OUT1, OUT2 are selected

SSR PID Control Enabled when OUT1, OUT2 are selected

SSR Cycle by PID Control Enabled when OUT1, OUT2 are selected

SSR Phase by PID Control Enabled when OUT1, OUT2 are selected

Current by PID Control Enabled when OUT1, OUT2 are selected

Relay ON/OFF Control Enabled when OUT3, OUT4 are selected

Relay ON/OFF by PID Control Enabled when OUT3, OUT4 are selected

ON/OFF deviation setup control for heating side (control output 1)

Output delay setup control for heating side (control output 1)

Setting the PID control cycle for heating side (control output 1)

Displayed only when the method of PID Pb setup control for heating side (control output 1) is

Displayed only when the method of PID Ti setup control for heating side (control output 1) is

Displayed only when the method of PID Td setup control for heating side (control output 1) is

Displayed only when the method of steady-state error correction control for heating side (control output 1) is

Maximum current output setup control for heating side (control output 1)

Minimum current output setup control for heating side (control output 1)

Setup - Cooling Side (Control Output 2)

Selection of Output Hardware for Cooling Side (Control Output 2)

Current or SSR output

out1, out2, out3, out4

Selection of Control Method for Cooling Side (Control Output 2)

SSR ON/OFF Control Enabled when OUT1, OUT2 are selected

SSR PID Control Enabled when OUT1, OUT2 are selected

SSR Cycle by PID Control Enabled when OUT1, OUT2 are selected

SSR Phase by PID Control Enabled when OUT1, OUT2 are selected

Current by PID Control Enabled when OUT1, OUT2 are selected

Relay ON/OFF Control Enabled when OUT3, OUT4 are selected

Relay ON/OFF by PID Control Enabled when OUT3, OUT4 are selected

ON/OFF deviation setup control for cooling side (control output 2)

Output delay setup control for cooling side (control output 2)

Setting the PID control cycle for cooling side (control output 2)

Displayed only when the method of PID Pb setup control for cooling side (control output 2) is

Displayed only when the method of PID Ti setup control for cooling side (control output 2) is

Displayed only when the method of PID Td setup control for cooling side (control output 2) is

Displayed only when the method of steady-state error correction control for cooling side (control output 2) is

Maximum current output setup control for cooling side (control output 2)

Minimum current output setup control for cooling side (control output 2)

Alarm Output 1 Setup

Selection of output hardware for Alarm Output 1

No selection, Relay, out3, out4

Selection of Alarm Type for Alarm Output 1

Upper limit alarm, Lower limit alarm, Upper/Lower limit alarm, Sensor error, Loop error (output error)

Selection of Alarm Hold for Alarm Output 1

Using the hold, Not using the hold

Selection of Initial Alarm Pass for Alarm Output 1

Using the pass, Not using the pass

Upper alarm temperature limit setup for Alarm Output 1

Lower alarm temperature limit setup for Alarm Output 1

Setting the output direction for Alarm Output 1

Alarm Output 2 Setup

Selection of output hardware for Alarm Output 2

No selection, Relay, out3, out4

Selection of Alarm Type for Alarm Output 2

Upper limit alarm, Lower limit alarm, Upper/Lower limit alarm, Sensor error, Loop error (output error)

Selection of Alarm Hold for Alarm Output 2

Using the hold, Not using the hold

Selection of Initial Alarm Pass for Alarm Output 2

Using the pass, Not using the pass

Upper alarm temperature limit setup for Alarm Output 2

Lower alarm temperature limit setup for Alarm Output 2

Setting the output direction for Alarm Output 2

Current Output 1 Setup

Selection of output hardware for Current Output 1

No selection, Current output, out1, out2

Selection of current output type for Current Output 1

Current temperature, Setting temperature, Controlled variable

The temperature at current output of 1.20mA

The temperature at current output of 1.4mA

Current Output 2 Setup

Selection of output hardware for Current Output 2

No selection, Current output, out1, out2

Selection of current output type for Current Output 2

Current temperature, Setting temperature, Controlled variable

The temperature at current output of 2.20mA

The temperature at current output of 2.4mA

8 Description of Control Output (Heating Output, Cooling Output)

For output of Product, hardware is selected by each function. Please select one from OUT1, OUT2, OUT3 and OUT4 for the control output.

| | | | | |
|--|--|--|---------------|---------------|
| Heating Side (Control Output 1) ON/OFF control PID control | OUT1 Current output and SSR enabled | OUT2 Current output and SSR enabled | OUT3 Relay | OUT4 Relay |
| Cooling Side (Control Output 1) ON/OFF control PID control | OUT1 Current output and SSR enabled | OUT2 Current output and SSR enabled | OUT3 Relay | OUT4 Relay |

System Setup

Input and Selection of Sensor Type

Garman Industrial Std PT100, Japanese Industrial Std PT100, K type thermocouple, N type thermocouple, T type thermocouple, J type thermocouple, E type thermocouple, NTC 10K low temp, NTC10K high temp, 0-100 mV voltage, 0-5V voltage, 1-5V voltage, 0-10V voltage, 0-20mA current, 4-20mA current

Function Setup for Digital Input 3

No use, Start/Stop, Alarm/Release, Auto tuning, Auto/Manual

Input Type Setup for Digital Input 1, 2, 3

NormalOpen, NormalClose

Unit of Temperature Display

No unit display, Display in Celsius, Display in Fahrenheit

Use/Use of the analog scale function

Upper limit of analog signal input, Lower limit of analog signal input

Upper limit of analog signal scale, Lower limit of analog signal scale

Decimal point position of analog signal scale

Setting the band

Setting the lamp change temp, Setting the lamp change time

Setting the loop error detection temp, Setting the loop error detection time

Function Setup for Digital Input 1, 2

Not using, Start/Stop function, Release Alarm function, Multi SV Input 1, Multi SV Input 2

ON/OFF Control

If OUT1, OUT2 are selected for hardware for the heating output and the cooling output to enable the ON/OFF control, the ON/OFF control is enabled by using SSR. If OUT3, OUT4 are selected, the ON/OFF control is enabled by using the relay.

The menu to select a control method **CSEL** shall be **SSrnf** if OUT1, OUT2 are selected, or **rLnF** if OUT3, OUT4 are selected.

ON/OFF Deviation Temperature Setup

Frequent ON/OFF operation for relay output will cause early deterioration of the output contact, or hunting (vibration, chattering) owing to external noise etc. To prevent such phenomenon, this function enables the setting of a specific gap between the ON and OFF output operations to protect the contact.

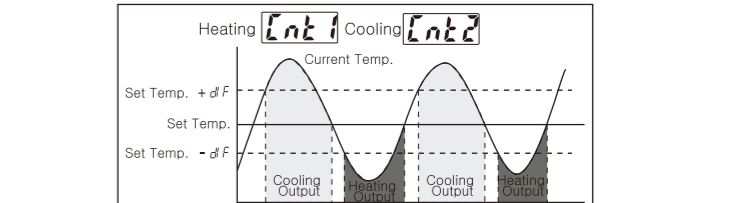
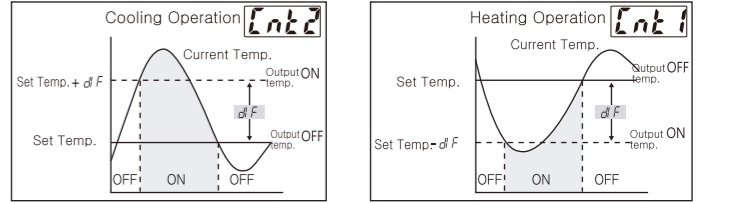

2 dLt Output Delay Setup

To be used if problems are foreseeable for the controlled object owing to frequent ON/OFF operation (such as freezer, compressor etc). Protecting the equipment during sudden power failure or re-connection to power.

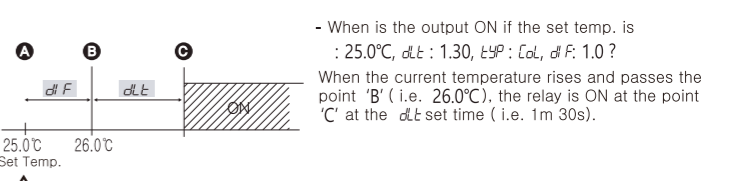

Caution
In case of ON/OFF control by SSR, use zero Crossing SSR to reduce noise generation.

ON/OFF by PID Control

The ON/OFF by PID control is similar to the general ON/OFF control methods. The outstanding difference is in that the ON time and the OFF time are adjusted in accordance with the controlled variable to facilitate the PID control.

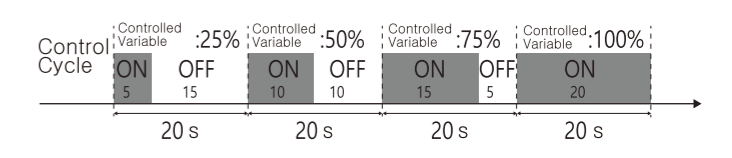

If OUT1, OUT2 are selected for hardware for the heating output and the cooling output the ON/OFF PID control is enabled by using SSR. If OUT3, OUT4 are selected, the PID control is enabled by using the relay.

The menu to select a control method **CSEL** shall be **SSrnf** if OUT1, OUT2 are selected, or it shall be **rLnF** if OUT3, OUT4 are selected.

The minimum ON/OFF time varies depending on the control cycle (CPT) in case of PID control by relay.

- If CPT control cycle is less than 5s: 0.3s; less than 10s: 0.5s; 10s or above: 1s
- The minimum ON/OFF time for PID control by SSR is 0.05s in all cases.

Caution
If the control cycle is too short for PID control by relay, frequent ON/OFF operations may shorten the relay contact life.

Caution
In case of ON/OFF PID control by SSR, use zero Crossing SSR to reduce noise generation.

3 CPT Control Cycle Setup

The ON and OFF operations are repeated for a set period of time within the set time cycle when performing the PID control using the relay or the SSR output. The said set time cycle is known as the control cycle.

4 Pb Proportional Band Width

The P controlled variable changes when the current temperature is within the proportional band width (PB).

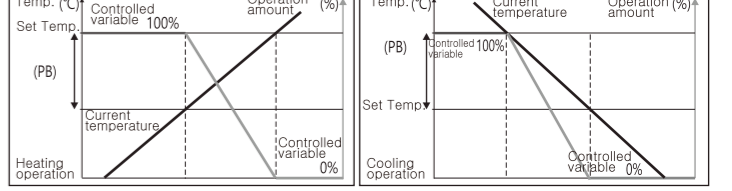

5 tI Integral Time

The differential time (TD) refers to the time when the operating amount as same as the proportional operation is obtained only by the differential operation during the uniform change in deviation. The differential operation monitors sudden deviations in disturbance, and adds the operating amount in case of large difference to the previous deviation to facilitate quick response to disturbance.

Caution: You are recommended to set the following menus first as there are menus that initialize other menu values depending on the setup values. Upon change of the following menus, please check again other menu values that were previously set.

- out1**: This is the menu to select one from OUT1, OUT2, OUT3 and OUT4 for the output hardware. You can initialize the method of control for the heating/cooling output (Auto Tuning is selected).
- CSEL**: This is the menu to change the method of control for the heating/cooling output. The hardware setup is changed in accordance with the selected control method. Tuning stops if Auto Tuning is selected.
- in**: This is the menu to change the input sensor. The following menus will be initialized: **SEt1**, **SEt2**, **RI nH**, **RI nL**, **RS eL**, **LS eL**, **dot**, **dF**.

Set temp., Scale, Upper limit for scale input, Lower limit for scale display, Upper limit for scale input, Lower limit for scale display, Scale decimal point, ON/OFF output deviation

Pb, **rSt**, **RdF**, **Cor**, **bAnd**, **rnPr**, **rPLr**, **noSF**

Proportional Band Width, Steady-state error correction, Alarm output deviation, Temp. sensor correction, Band setting, Lamp change temperature, Loop error detection, No over shoot

- * TI too low: Vibration on a regular basis may occur.
- * TI too high: The target temperature cannot be reached easily, or it may take too long to reach.
- * TI = 0: The integral operation is disabled.

6 **td** Differential Time (TD)

The differential time (TD) refers to the time when the operating amount as same as the proportional operation is obtained only by the differential operation during the uniform change in deviation. The differential operation monitors sudden deviations in disturbance, and adds the operating amount in case of large difference to the previous deviation to facilitate quick response to disturbance.

- * TD too low: Slow response to disturbance
- * TD too high: Vibration on a regular basis may occur..
- * TD = 0: The differential operation is disabled.

7 **rSt** Steady-state Error Correction

This is applicable when the proportional operation is used only. With the proportional operation only, the target temperature cannot be reached and there exists a steady-state error. The deviation can be corrected using this menu.

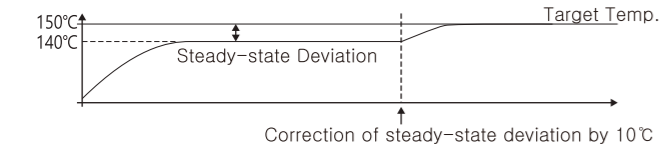

PID SSR Cycle Control

The PID SSR cycle control uses a Non Zero Crossing type SSR, making outputs by adjusting the number of ON/OFF operations in unit of one cycle of AC power according to the controlled variable. This method can lower the open/close noise compared to the zero crossing AC power control for the phase control, and facilitate more accurate control as the control cycle is variable to the optimum ratio instead of it being fixed.

Select OUT1, OUT2 for the heating and cooling output hardware for the cycle control.

To enable the cycle PID control with SSR, SSR must be of the Non Zero -Crossing type and its reaction speed must be within 1ms.

⚠ Caution

In order to detect the zero pass of the load power in the product, when applying NonZero Crossing type SSR, product operation power and load must be common power.

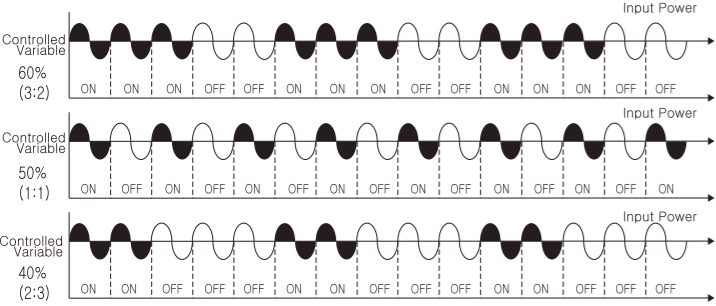

PID SSR Phase Control

The PID SSR phase control uses a Non Zero Crossing type SSR, controls the phase within a half cycle of AC power in accordance with the controlled variable, and facilitates the continuous control of the load power. In general, a power regulator may be used for phase control, but it is expensive and bulky. SSR is an economic and efficient substitute.

Select OUT1, OUT2 for the heating and cooling output hardware for the phase control.

In the control method selection menu **[SEL]**, select **[SPPd]**.

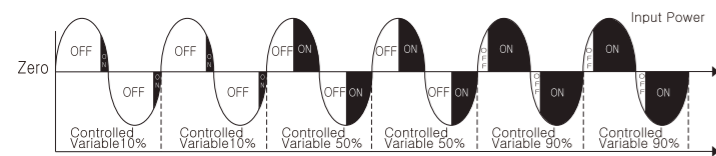

⚠ Caution

To enable the PID control with SSR, SSR must be of the non zero-crossing type and its reaction speed must be within 1ms.

⚠ Caution

The Product's operation power and the load must be the same as the zero pass of load power must be detected within the Product.

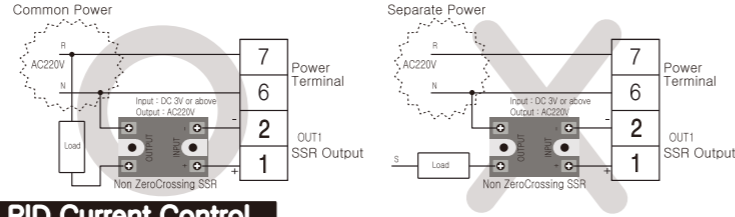

PID Current Control

The PID current control efficiently stabilizes the current temperature to the target temperature by adjusting the current output (4-20mA) in accordance with the controlled variable. The output current is controlled by the continuous analog output. Select OUT1, OUT2 for the heating and cooling output hardware for the PID current control.

In the control method selection menu **[SEL]**, select **[APd]**.

⚠ Caution

The load resistance during the use of current output shall be 500 ohm or below.

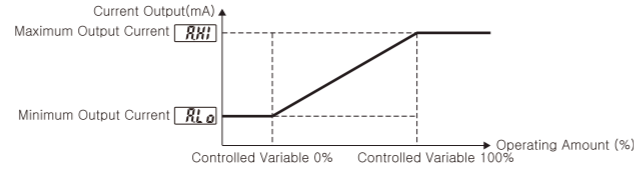

8 **RHl** Maximum Current Output Setup

This refers to the current output during the PID current control at 100% operating amount.

Example) If A.HI is 15.0mA, the current output is 15.0mA at 100% operating amount.

RLo Minimum Current Output Setup

This refers to the current output during the PID current control at 0% operating amount.

Example) If A.LO is 5.0mA, the current output is 5.0mA at 0% operating amount.

PID Operation Type

9 **PIdt** PID Operation Type Setup

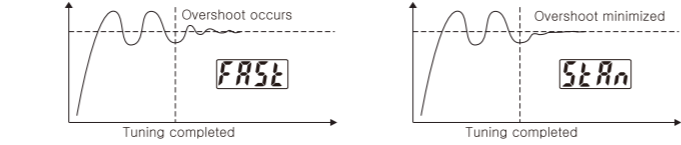

In FAST mode, the target temperature is reached faster, even if there is some overshoot. In STANDARD mode, the target temperature is reached while minimizing overshoot.

PID tuning temperature setup

10 **noSF** No over shoot tuning deviation temperature setup

In auto tuning operation, tuning is performed at a distance of NO overshoot tuning deviation temperature from the set temperature to reach the set temperature so that the current temperature does not exceed the set temperature. (It does not apply when using heating / cooling simultaneously.)

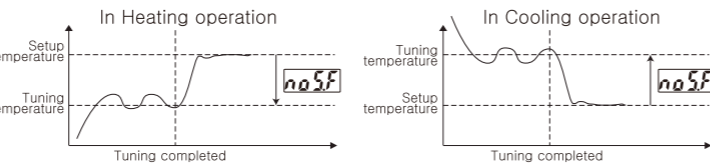

Band Function

11 **bRnd** Band Function Setup

You can designate a zone between the heating control and the cooling control when both the heating and cooling outputs are used. This does not apply if the set value is 0. If the set value is "+" a zone having 0% of the controlled variable for both the heating and the cooling sides will be created. If the set value is "-" a zone where the control for the heating and the cooling sides are overlapped is created.

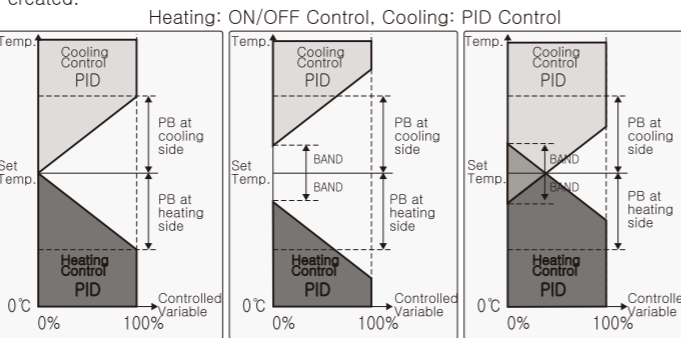

bRnd is set to "0" Based on the set temperature, a zone having the controlled variable of 0 is created.

bRnd is set to "+" Based on the set temperature, a zone having the controlled variable of 0 is created.

bRnd is set to "-" Based on the set temperature, a zone with the heating and cooling controls overlapped is created.

Heating: PID Control, Cooling: ON/OFF Control

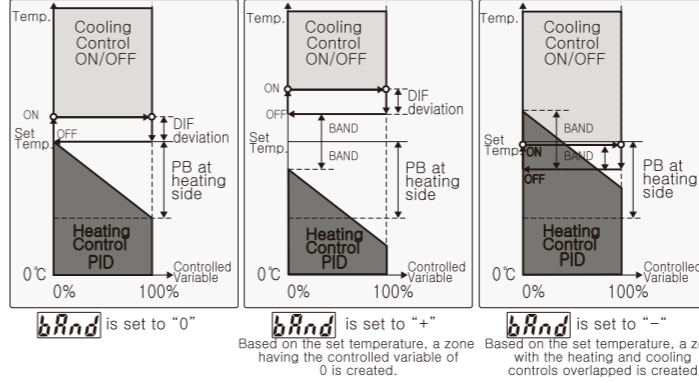

Heating: ON/OFF Control, Cooling: PID Control

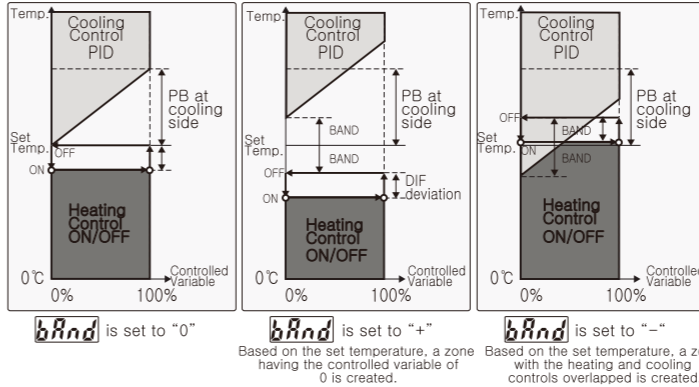

Heating: ON/OFF Control, Cooling: ON/OFF Control

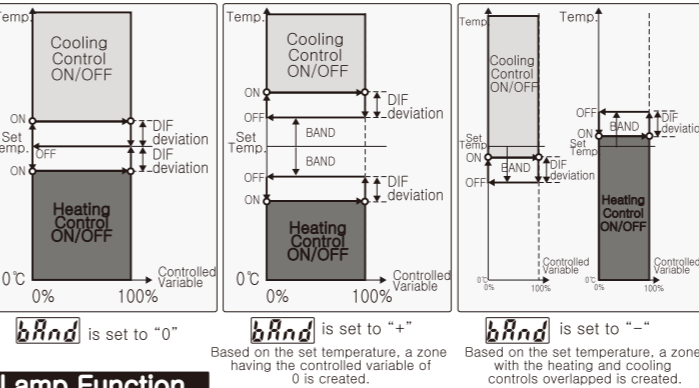

Lamp Function

The lamp function is used to prevent sudden temperature changes when the setting values are changed, typically at sites where such changes cause concerns with respect to the controlled object.

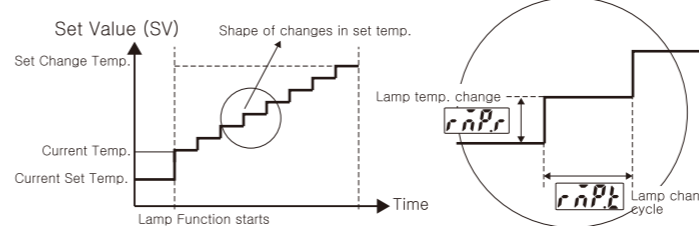

12 **rnPc** Lamp Temperature Change

This is the temperature value used to be added to or subtracted from the set temperature at each time of lamp change when the lamp function is started.

Example:
Lamp temperature change: 5°C, Current set temp.: 10°C, Set target temp.: 50°C
Lamp changing time: 1min.
The set temperature is increased by 5°C every minute and the lamp stops when the temperature reaches to 50°C.

13 **rnPt** Lamp Change Time

This menu is used to change the lamp temperature at every set time when the lamp function is started. The lamp function is disabled if the set value is "0".

9 Alarm Output (Alarm Output 1, Alarm Output 2)

For output of Product, hardware is selected by each function. Please select one from OUT1, OUT2, OUT3 and OUT4 for the alarm output.

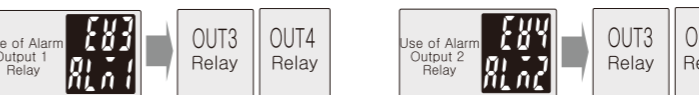

Upper Limit Alarm

14 **ALH** shall be selected for the **ALYP** menu to use this function. An alarm is given when the current temperature rises above the set upper limit alarm temperature. The temperature must drop by the set ADF value to release the alarm. The upper limit alarm temperature shall be set in the **[KPr]** menu.

Lower Limit Alarm

15 **ALL** shall be selected for the **ALL** menu to use this function. An alarm is given when the current temperature drops below the set lower limit alarm temperature. The temperature must rise by the set ADF value to release the alarm. The lower limit alarm temperature shall be set in the **[LPr]** menu.

Upper and Lower Limit Alarm

16 **ALHL** shall be selected for the **ALYP** menu to use this function. An alarm is given when the current temperature rises above the set upper limit alarm temperature or drops below the set lower limit alarm temperature. The upper limit alarm and the lower limit alarm can be used simultaneously.

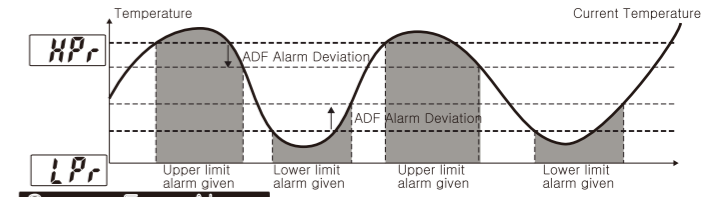

Sensor Error Alarm

- o-E** The sensor connection is poor or the cable is cut.
- 5-E** The sensor cable is short. Check the wiring.
- 1-E** The cold junction compensation sensor for the thermocouple is defective. Contact the manufacturer for A/S.

XXXX Analog signals (mV, V, mA etc) are entered outside the given upper limits.

LLLL Analog signals (mV, V, mA etc) are entered outside the given lower limits.

Loop Break Alarm

It is normal that the temperature changes when the controlled variable is 0% or 100% for the heating or the cooling device. If however, the temperature does not change, the output device may be faulty.

17 **rPLr** Loop Error Detection Temperature

Set the range of temperature change for the temperature to be changed within the detection time when the loop error detection function is started.

Example:
Loop error detection time = 5min. Loop error detection temp. = 2°C
=> An alarm is to be given when there is no temperature change by a minimum of 2°C within 5 minutes while the controlled variable is 0% or 100%

18 **rPLt** Loop Error Detection Time

Set the detection time to detect loop error. An alarm is given when there is no temperature change by the set detection temperature within the set time while the controlled variable is 0% or 100%. The loop error detection function is disabled if the set value is "0".

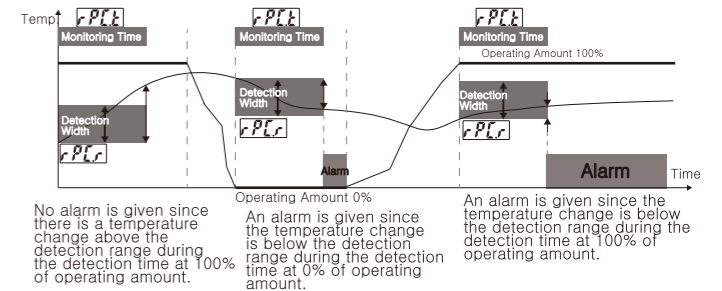

No alarm is given since there is a temperature change above the detection range during the detection time at 0% of operating amount.

An alarm is given since the temperature change is below the detection range during the detection time at 0% of operating amount.

An alarm is given since the temperature change is below the detection range during the detection time at 100% of operating amount.

Alarm Hold Function

19 When **ALHd** is:
Set to **no**: The corresponding alarm output is OFF when the alarm is released.
Set to **YES**: The corresponding alarm output remains ON even if the alarm is released.
=> The alarm is released by re-connecting power, if the external digital input is designated as the alarm release function, the alarm is released by the operation of the corresponding key.

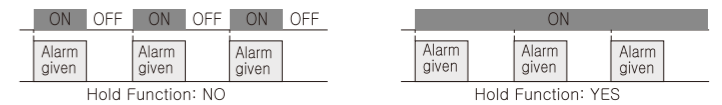

Alarm Pass Function

- 21 If **PRSS** is:
 Set to **no**: The corresponding alarm output is ON at the first alarm event after power on.
 Set to **YES**: The corresponding alarm output is not ON at the first alarm event after power on.

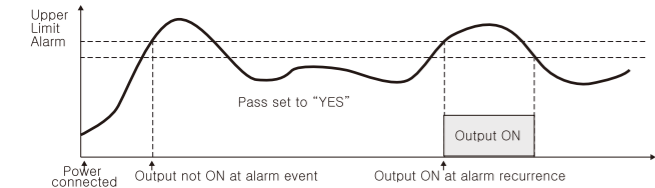

Output Direction Setup

- 22 If **noal** is set to **no**: Output OFF at normal operation; Output ON at alarm event
 If **al**: Output ON at normal operation; Output OFF at alarm event

10 Current Transmission (Output 1, Output 2)

For output of Product, hardware is selected by each function. Please select one from OUT1 and OUT2 for the current transmission output.

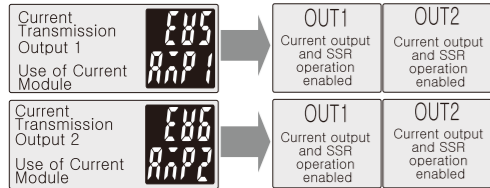

Transmission of Current Temperature

- 23 The current temperature can be transmitted to current when **ALr5** is set to **PRK**.

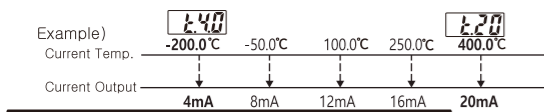

Transmission of Set Temperature

- 24 The set temperature can be transmitted to current when **ALr5** is set to **SRK**.

Transmission of Controlled Variable

- 25 The Controlled Variable can be transmitted when **ALr5** is set to **CKtL**.

11 Analog Scale Function

The analog scale function is used to display the analog signal input value reduced to the minimum or expanded to the maximum value as designated.

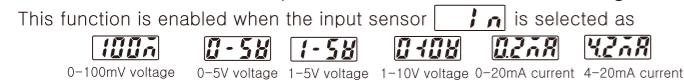

- 26 The analog scale function is enabled when **SCALE** is set to **YES**.

- 27 **RI nH** is the menu to set the maximum value of the input analog signal.

- 28 **RI nL** is the menu to set the minimum value of the input analog signal.

- 29 **RSCL** is the expanded or the reduced value displayed when the analog signal input is **RI nH**.

- 30 **LSCL** is the expanded or the reduced value displayed when the analog signal input is **RI nL**.

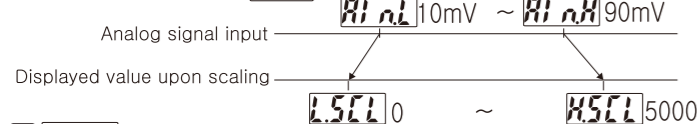

- 31 **dot** is the menu to set a decimal point of the displayed value upon scaling of the analog input signal.

12 Digital Input

General functions of the controller can be controlled by connecting an external switch.

Caution

General functions can be controlled by the key on the controller, but they are disabled if they are set by external input.

Terminal Wiring

How to use the switch according to the digital switch function setting

| | | |
|--|------------------------|--|
| If set to the Start/Stop function | Use the Select switch. | |
| If set to the Release Alarm function | Use the Push switch. | |
| If set to Select Auto/Manual Mode function | Use the Select switch. | |
| If set to the Auto Tuning function | Use the Push switch. | |
| If set to the Multi SV function | Use the Select switch. | |

The Select switch is a type where singles are maintained when the switch is turned on. The Push switch is a type where signals are not maintained when the switch is pressed and released.

- 32 **di 01 di 02 di 03** Functions of external switches can be set.

- no** NO: The corresponding switch is not to be used.

- rst** Start/Stop: If this is set to "Stop" all outputs are turned OFF and "Stop" is displayed.

- rela** Release Alarm: The alarm output is OFF when this switch is pressed while the alarm output is ON.

- Auto** Auto Tuning: The auto tuning refers to the process of identifying a suitable control coefficient for auto control. Operate the switch to start or stop tuning.

- ALrA** Select Auto/Man: The Auto mode facilitates an accurate control by automatic calculation of the controlled variable. The Manual mode facilitates the direct setup of the controlled variable.

- ALrA ALrB** Multi SV: The set temperature can be designated from Set Temp. 1 to Set Temp. 4.

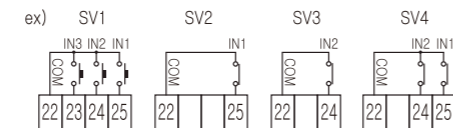

If there is no external input signal, it operates with SV1 set value.

- 33 **1 2 P 1 1 2 P 2 1 2 P 3** The input type of external switch can be set.

- When set to **no**: Normally OFF, but turns ON when the switch is pressed.

- When set to **nl**: Normally ON, but turns OFF when the switch is pressed.

13 Input Sensor and Others

- 34 **in** is used to select an input sensor.

- 35 **Cor** is used to correct the difference between the displayed value by the input sensor and other precision device.

Example:
 Current temp. = 20°C, The temp. by precision device: 22°C
 => COR correction value: Enter "2°C" and the current temperature is displayed as "22°C".

- 36 **Unit** is used to change the unit of display of the input sensor. This menu is enabled only when the input sensor is designate as the temperature sensor. You can select either Celsius or Fahrenheit.

14 Communication

- * The RS485 MODBUS RTU type protocol is embedded.
- * Non-synch 2-line half duplex communication method
- * Communication distance: within 1.2km
- * Communication speed: 1200 / 2400 / 4800 / 9600 / 19200Bps
- * Start bit: 1 bit; Stop bit: 1 bit; Parity bit: None; Data bit: 8 bit

- 37 **Addr** is used to set the RS485 communication address.

- 38 **bPS** is used to set the RS485 communication speed.

< Func 0x02 : Read Discrete Inputs >

Brief information (such as the controller status) can be received in the bit format.

| NO | Address | Description | Range | Unit | Default Value |
|--------|---------|------------------------------------|--------------------------------------|------|---------------|
| 100001 | 0000 | Sensor Open Error | 0 / 1 | | |
| 100002 | 0001 | Sensor Short Error | 0 / 1 | | |
| 100003 | 0002 | Cold Joint Correction Sensor Error | 0 / 1 | | |
| 100004 | 0003 | Auto Tuning | 0: No tuning / 1: Tuning in progress | | |
| 100005 | 0004 | Output at heating side | 0: Off / 1: On | | |
| 100006 | 0005 | Output at cooling side | 0: Off / 1: On | | |
| 100007 | 0006 | Alarm Output 1 | 0: Off / 1: On | | |
| 100008 | 0007 | Alarm Output 2 | 0: Off / 1: On | | |
| 100009 | 0008 | Temp. Unit in Celsius | 0: No unit / 1: Celsius | | |
| 100010 | 0009 | Temp. Unit in Fahrenheit | 0: No unit / 1: Fahrenheit | | |
| 100011 | 000A | Start/Stop | 0: Stop / 1: Start | | |
| 100012 | 000B | Alarm Release Input | 0: No input / 1: Release input | | |
| 100013 | 000C | Auto mode | 0: Non automatic / 1: Auto mode | | |
| 100014 | 000D | Manual mode | 0: Non manual / 1: Manual mode | | |
| 100015 | 000E | Multi SV1 | 0: No / 1: SV1 | | |
| 100016 | 000F | Multi SV2 | 0: No / 1: SV2 | | |
| 100017 | 0010 | Multi SV3 | 0: No / 1: SV3 | | |
| 100018 | 0011 | Multi SV4 | 0: No / 1: SV4 | | |
| 100019 | 0012 | Heating control use/unuse | 0: Not use / 1: Use | | |
| 100020 | 0013 | Cooling control use/unuse | 0: Not use / 1: Use | | |
| 100021 | 0014 | Alarm Output 1 use/unuse | 0: Not use / 1: Use | | |
| 100022 | 0015 | Alarm Output 2 use/unuse | 0: Not use / 1: Use | | |
| 100023 | 0016 | Current output 1 use/unuse | 0: Not use / 1: Use | | |
| 100024 | 0017 | Current output 2 use/unuse | 0: Not use / 1: Use | | |
| 100025 | 0018 | Analog scale | 100025 100025 00: 0000 01: 000.0 | | |
| 100026 | 0019 | decimal point position | 0019 10019 10: 00.00 11: 0.000 | | |

< Func 0x04 : Read Inputs Registers >

Able to receive simple information such as current temperature, sensor status, and output status.

| NO | Address | Description | Range | Unit | Default Value |
|--------|---------|---------------|-----------------------------|------|---------------|
| 300001 | 0000 | Current Temp. | If in a sensor error: -5000 | °C | |

| NO | Address | Description | Range | Unit | Default Value | | | |
|--------|---------|----------------------------------|---|-----------------|------------------------------------|---------------------------------|----|--|
| 300002 | 0001 | Input Sensor Type | 0: DPT100 / 1: JPT100 | Thermo resistor | | | | |
| | | | 2: TC.K / 3: TC.N | Thermo-couple | | | | |
| | | | 4: TC.T / 5: TC.J | Thermo-couple | | | | |
| | | | 6: TC.E | Thermo-couple | | | | |
| | | | 7: NTC LT / 8: NTC HT | NTC | | | | |
| | | | 9: 0~100mV / 10: 0~5V | Voltage | | | | |
| | | | 11: 1~5V / 12: 0~10V | Voltage | | | | |
| | | | 13: 0~20mA / 14: 20mA | Current | | | | |
| | | | The lamp temperature in case the lamp function is in operation. | | | °C | | |
| | | | 300003 | 0002 | Current Set Temp. | | °C | |
| | | | 300004 | 0003 | Controlled variable - heating side | 0.0 ~ 100.0 | % | |
| | | | 300005 | 0004 | Controlled variable - cooling side | 0.0 ~ 100.0 | % | |
| | | | 300006 | 0005 | System Status bit(100016-100001) | Func 0x02: Read Discrete Inputs | | |
| 300007 | 0006 | System Status bit(100026-100017) | Func 0x02: Read Discrete Inputs | | | | | |
| 300008 | 0007 | Model Name | 0x5037('P', '7') | | | | | |
| 300009 | 0008 | Model Name | 0x3030('0', '0') | | | | | |
| 300010 | 0009 | Model Name | 0x0000 | | | | | |

| NO | Address | Description | Range | Unit | Default Value |
|--------------|---------|--------------------|-------|------|---------------|
| 300006(0005) | | System Status(bit) | | | |
| 300007(0006) | | System Status(bit) | | | |

< Func 0x03 : Read Hoding Registers > < Func 0x06 :Write Single Registers >

You can read the controller setting menu. You can change the controller setting menu, each one menu.

< Func 0x10 :Write Multiple Registers >

You can change many controller setting menus.

| NO | Address | Description | Range | Unit | Default Value |
|--------|---------|--|--|------|----------------------------------|
| 400001 | 0000 | Sensor information | Func 0x04: Read Inputs Registers Refer to item 3000002 | | 0: DPT100 |
| 400002 | 0001 | PID Operation type | 0: Standard operation, 1: High speed operation | | 0: Standard operation |
| 400003 | 0002 | No over shoot tuning deviation setup | 0.0 ~ 30.0C | °C | 0.0°C |
| 400004 | 0003 | Multi SV1 | Varies depending on the input sensor. DPT100, JPT100: -199.9~400.0°C K,N,J: -50 ~ 1200°C T: -50 ~ 400°C E: -50 ~ 1000°C | | |
| 400005 | 0004 | Multi SV2 | NTC Low temp.: -55.0 ~ 99.9°C NTC high temp.: -20.0 ~ 250.0°C mV: 0.0 ~ 100.0mV 0~5V: 0.00 ~ 5.00V 1~5V: 1.00 ~ 5.00V | | 0 |
| 400006 | 0005 | Multi SV3 | 0~10V: 0.00 ~ 10.00V 0~20mA: 0.00 ~ 20.00mA 4~20mA: 4.00 ~ 20.00mA | | |
| 400007 | 0006 | Multi SV4 | | | |
| 400008 | 0007 | Manual Controlled Variable at Heating Side | The controlled variable in Man Mode at heating side | % | 0 |
| 400009 | 0008 | Manual Controlled Variable at Cooling Side | The controlled variable in Man Mode at cooling side | % | 0 |
| 400010 | 0009 | Heating control output number | OUT1 / OUT2 / OUT3 / OUT4 | | OUT1 |
| 400011 | 000A | Cooling control output number | OUT1 / OUT2 / OUT3 / OUT4 | | OUT2 |
| 400012 | 000B | Output number for alarm output 1 | OUT3 / OUT4 | | OUT3 |
| 400013 | 000C | Output number for alarm output 2 | OUT3 / OUT4 | | OUT4 |
| 400014 | 000D | Output number current transmission 1 | OUT1 / OUT2 | | NO |
| 400015 | 000E | Output number current transmission 2 | OUT1 / OUT2 | | NO |
| 400016 | 000F | Control type for heating side | 0: SSR ON/OFF control 1: SSR ON/OFF PID control 2: SSR Cycle PID control 3: SSR Phase PID control 4: Current PID control 5: Relay ON/OFF control 6: Relay ON/OFF PID control | | 1: SSR ON/OFF PID control |
| 400017 | 0010 | Control type for cooling side | | | 0: SSR ON/OFF control |
| 400018 | 0011 | ON/OFF deviation at heating side | 0.1 ~ 20.0 | °C | 1.0 |
| 400019 | 0012 | ON/OFF deviation at cooling side | 0.1 ~ 20.0 | °C | 1.0 |
| 400020 | 0013 | Output delay at heating side | 0 ~ 1999 | sec. | 0 |
| 400021 | 0014 | Output delay at cooling side | 0 ~ 1999 | sec. | 0 |
| 400022 | 0015 | Control cycle at heating side | 0 ~ 120 | sec. | 20 |
| 400023 | 0016 | Control cycle at cooling side | 0 ~ 120 | sec. | 20 |
| 400024 | 0017 | PB at heating side | 0 ~ 30.0 | °C | 10.0 |
| 400025 | 0018 | PB at cooling side | 0 ~ 30.0 | °C | 10.0 |
| 400026 | 0019 | TI at heating side | 0 ~ 9999 | sec. | 0 |
| 400027 | 001A | TI at cooling side | 0 ~ 9999 | sec. | 0 |
| 400028 | 001B | TD at heating side | 0 ~ 9999 | sec. | 0 |
| 400029 | 001C | TD at cooling side | 0 ~ 9999 | sec. | 0 |
| 400030 | 001D | Steady state error correction at heating | -30.0 ~ 30.0 | °C | 0 |
| 400031 | 001E | Steady state error correction at cooling | -30.0 ~ 30.0 | °C | 0 |
| 400032 | 001F | Max current output at heating side | 0 ~ 20.0 | mA | 20.0 |
| 400033 | 0020 | Max current output at cooling side | 0 ~ 20.0 | mA | 20.0 |
| 400034 | 0021 | Min current output at heating side | 0 ~ 20.0 | mA | 4 |
| 400035 | 0022 | Min current output at cooling side | 0 ~ 20.0 | mA | 4 |
| 400036 | 0023 | Alarm type - Alarm Output 1 | 0: Upper limit alarm output 1: Lower limit alarm output 2: Upper and lower limits alarm output 3: Sensor error output 4: Loop error output | | Upper limit alarm |
| 400037 | 0024 | Alarm type - Alarm Output 2 | | | Lower limit alarm |
| 400038 | 0025 | Alarm Hold - Alarm Output 1 | 0: No hold, 1: Hold enabled | | 0: No hold |
| 400039 | 0026 | Alarm Hold - Alarm Output 2 | 0: No hold, 1: Hold enabled | | 0: No hold |
| 400040 | 0027 | Initial Alarm Pass - Alarm Output 1 | 0: No pass, 1: Pass the initial alarm | | 0: No pass |
| 400041 | 0028 | Initial Alarm Pass - Alarm Output 2 | 0: No pass, 1: Pass the initial alarm | | 0: No pass |
| 400042 | 0029 | Upper limit alarm - Alarm Output 1 | Refer to 400002 "Multi SV". | °C | Max Multi SV |
| 400043 | 002A | Upper limit alarm - Alarm Output 2 | Refer to 400002 "Multi SV". | °C | Max Multi SV |
| 400044 | 002B | Lower limit alarm - Alarm Output 1 | Refer to 400002 "Multi SV". | °C | Min. Multi SV |
| 400045 | 002C | Lower limit alarm - Alarm Output 2 | Refer to 400002 "Multi SV". | °C | Min. Multi SV |
| 400046 | 002D | Alarm deviation - Alarm Output 1 | 0.1 ~ 20.0 | °C | 0.1 |
| 400047 | 002E | Alarm deviation - Alarm Output 2 | 0.1 ~ 20.0 | °C | 0.1 |
| 400048 | 002F | Output direction - Alarm Output 1 | 0:Normal Open, 1:NormalClose | °C | 1:NormalOpen |
| 400049 | 0030 | Output direction - Alarm Output 2 | 0:Normal Open, 1:NormalClose | °C | 1:NormalOpen |
| 400050 | 0031 | Transmission type - Transmission output 1 | 0: Transmission of current temp. 1: Transmission of set temp. 2: Transmission of controlled variable | | 0: Transmission of current temp. |
| 400051 | 0032 | Transmission type - Transmission output 2 | | | 1: Transmission of set temp. |
| 400052 | 0033 | 20mA data - Transmission output 1 | Refer to 400004 "Multi SV". | °C | Max Multi SV |
| 400053 | 0034 | 20mA data - Transmission output 2 | Refer to 400004 "Multi SV". | °C | Max Multi SV |
| 400054 | 0035 | 4mA data - Transmission output 1 | Refer to 400004 "Multi SV". | °C | Min. Multi SV |
| 400055 | 0036 | 4mA data - Transmission output 2 | Refer to 400004 "Multi SV". | °C | Min. Multi SV |
| 400056 | 0037 | RS485 Comm. Address | 1 ~ 99 | | 1 |

| NO | Address | Description | Range | Unit | Default Value |
|--------|---------|-------------------------|---|------|------------------|
| 400057 | 0038 | RS485 Comm. Speed | 1200/2400/4800/9600/19200 | | 9600 |
| 400058 | 0039 | Sensor input correction | -20.0 ~ 20.0 | | 0.0 |
| 400059 | 003A | Digital input 1 | 1: Unuse, 1: Start/Stop 2: Release alarm, 3: Auto/Man 4: Auto Tuning, 5: Multi SV A | | 1: Start/Stop |
| 400060 | 003B | Digital input 2 | 1: Unuse, 1: Start/Stop 2: Release alarm, 3: Auto/Man 4: Auto Tuning, 5: Multi SV B | | 2: Release alarm |
| 400061 | 003C | Digital input 3 | 1: Unuse, 1: Start/Stop 2: Release alarm, 3: Auto/Man 4: Auto Tuning | | |