

CONOTEC

CONOTEC CO., LTD.
DIGITAL TEMPERATURE CONTROLLER



DESIGN REGISTRATION NO. 0316273
UTILITY MODEL NO. 0301508

FOX-1H, 1SH

Instruction Manual



FOX-1SH(R)
(Temperature and Humidity sensor)

FOX-1H
(Humidity sensor)

- A user manual for this product is posted on the company website.
- Please download the technical document and communications manual on the company website

01 Safety precautions

Please read the safety precautions carefully for correct operation of the product.

- ※ The specifications and dimensions specified in this instruction manual may be changed without any notice for performance enhancement.

⚠ Warning

1. This product was not made as a safe device. Therefore, this product should be attached with dual safety devices if it is used for the control purposes (e.g. a device vulnerable to accident and property damage, etc.).
2. Do not wire, inspect or service this product while the power is being supplied.
3. You must attach this product to a panel. Otherwise, it may cause an electric shock.
4. When connecting the power, you must check the terminal number.
5. Do not ever disassemble, process, modify or repair this product.

⚠ Caution

1. Please make yourself familiar with all the operation instructions, safety precautions and warnings before using this product. Comply with related specifications and capacity requirements
2. Do not wire or install this product to any unit with high inductive load (e.g. motor, solenoid, etc.).
3. Use a shielded cable with a proper length when extending a sensor.
4. Do not use any part that generates an arc when used in the same power or directly switched in close proximity.
5. Keep the power cable away from a high-voltage cable and do not install this product in any place that is full of water, oil and dust.
6. Do not install this product in any place that is exposed to direct sunlight or rain.
7. Do not install this product in any place that is subject to strong magnetic power, noise, vibration or shock.

8. Keep this product away from any place that generates strong alkaline or acid substances. Use a separate pipe.
9. Do not sprinkle water onto this product for cleaning when installing it in the kitchen.
10. Do not install this product in any place where the temperature/humidity ratings are exceeded
11. The sensor cable should not be cut or cracked..
12. Keep the sensor cable away from a signal cable, a power cable or a load cable. Use a separate pipe.
13. Keep in mind that the follow-up service will not be available if this product has been arbitrarily disassembled and modified
14. ⚠ symbol on the terminal wiring diagram indicates a safety statement that alerts a warning or caution.
15. Do not use this product near any device generating strong high-frequency noise (e.g. high-frequency welding machine, high-frequency sewing machine, high-frequency radio, large-capacity SCR controller, etc.).
16. Using this product in any method other than those specified by the manufacturer may lead an injury or a property damage
17. The product is not a toy. Keep it away from children.
18. The product should be installed only by an expert or a qualified person.
19. The company will not be liable for any damage caused by the violation of the above warnings and cautions or by a consumer's fault

⚠ Danger

Caution: Risk of electric shock

- Electric shock - Do not touch the AC terminal while the current is flowing. It may cause an electric shock.
- Please intercept input power surely when input power check

02 Model Types

Model	Sensor	Output	Humidity Range	RS485 Communications
FOX-1H	HCPV-220H	1c 250Vac2A	10%~95%Rh	Not supported
FOX-1SH	DS-SH series	1a 250Vac2A	0%~100%Rh	supported
FOX-1SHR				

03 Components

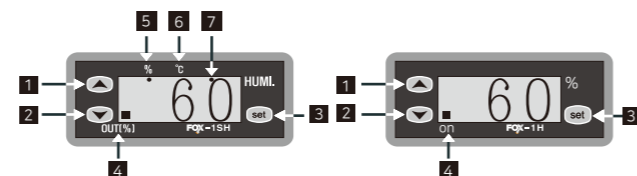

- 1 UP switch
- 2 Down switch
- 3 Set switch
- 4 Output display
- 5 Humidity display (FOX-1SH(R) model)
- 6 Temperature display (FOX-1SH(R) model)
- 7 Sensor communication status display

* The communication status light blinks when sensor communication is not smooth.

FOX-1SH(R) : Humidity display and control + Temperature display

The current status display has two modes and UP (increase)/DN(decrease) switches can change "humidity display/temperature display".

FOX-1H : Humidity display and control function

04 Terminal wiring diagram

[FOX-1SH / FOX-1SHR]

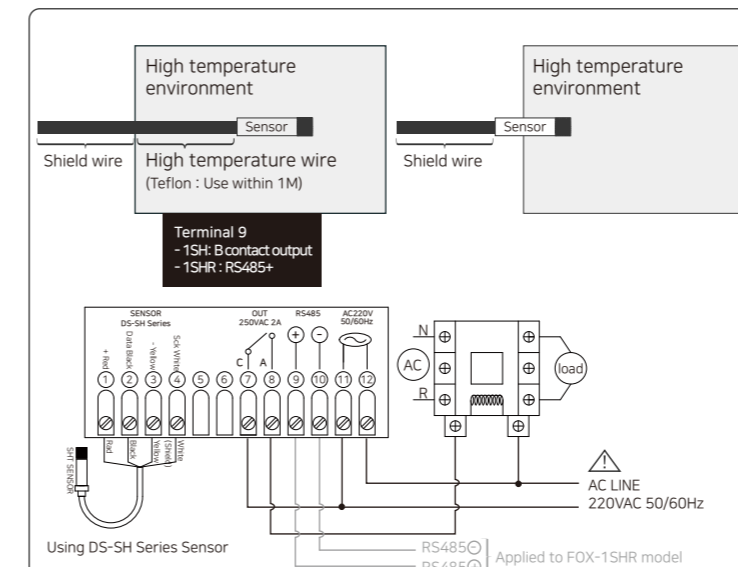

Ref1. Detailed specifications for the applicable sensor specifications, see the back of the '10.sensor's specifications.'

Caution1. Please make use of the shield wire when lengthening of the sensor wire, and in case of using in the high temperature range of 65°C~80°C, surely use the high temperature using wire(Teflon wiring).

Caution2. Please make the operating machine(load) be driven with using the power relay or magnet outside surely because its output specification of inside relay is less than 250VAC 2A.

[FOX-1H]

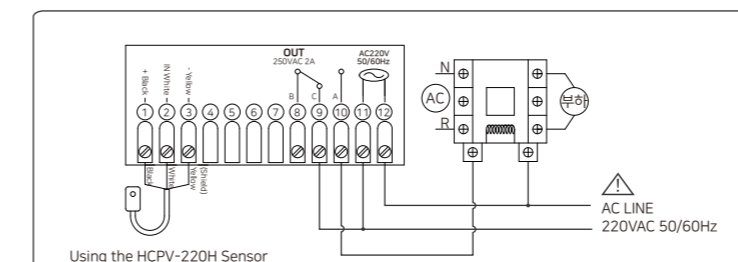

Ref1. Detailed specifications for the applicable sensor specifications, see the back of the '10.sensor's specifications.'

Caution1. Please make the operating machine(load) be driven with using the power relay or magnet outside surely because its output specification of inside relay is less than 250VAC 2A.

05 Program setting method (FOX-1SH(R))

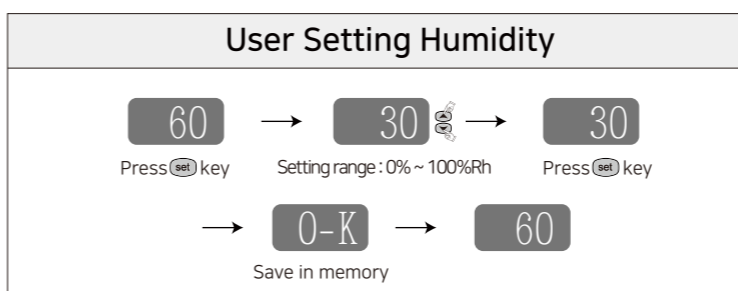

Humi./Temp.mode changing

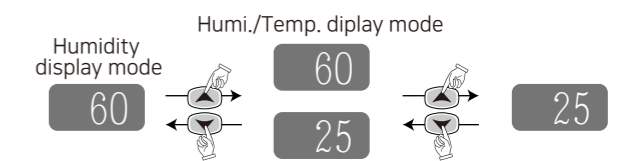

Caution1. The FOX-1SH(R) product is a humidity controller, but temperature is indicated as an add-ons. The temperature is display only, please note that control is not.

Program Setting (The value of each item is the factory setting.)

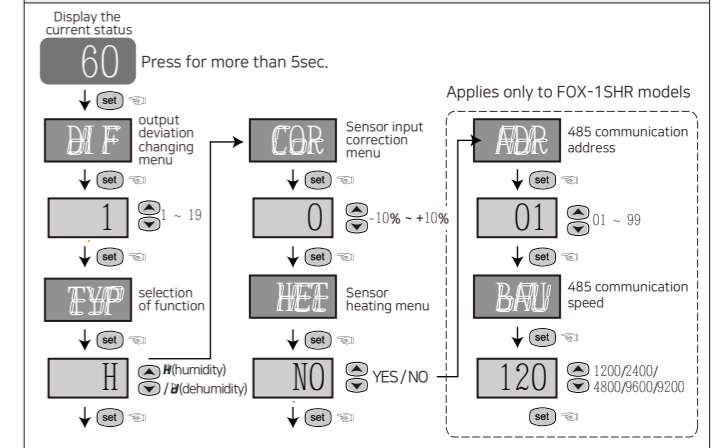

Ref 1. Press the SET key continuously for at least 5 seconds in the current humidity/temperature display to enter program setting mode.

Ref 2. All programs continue to press the SET key for at least 3 seconds after the setup ends, or after 60 seconds after the setup, the O-K character is automatically displayed and returns to the current humidity display state.

06 Program setting method (FOX-1H)

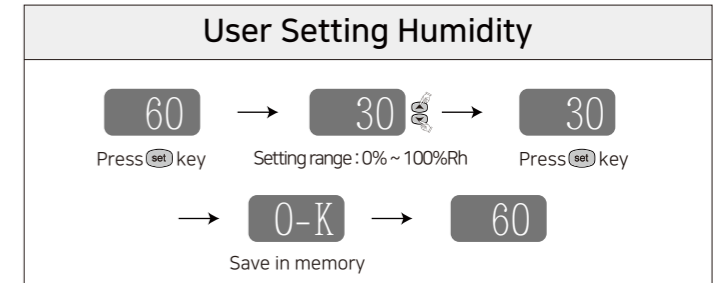

Program Setting (The value of each item is the factory setting.)

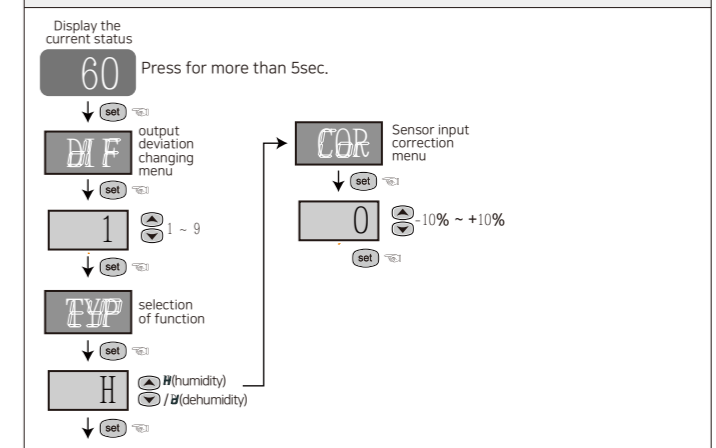

Ref 1. Press the SET key continuously for at least 5 seconds in the current humidity/temperature display to enter program setting mode.

Ref 2. All programs continue to press the SET key for at least 3 seconds after the setup ends, or after 60 seconds after the setup, the O-K character is automatically displayed and returns to the current humidity display state.

07 Function details

DIF : Set Output Deviation **FOX-1H FOX-1SH FOX-1SHR**

- Frequent On and OFF will shorten the lifespan of the relay or the output contact or cause hunting (generation, chattering) by noise from outside.
- To prevent the occurrence, the function protects the contact light of the equipment by setting an interval between ON and OFF in ON/OFF control.

TYP : Output Type Settings **FOX-1H FOX-1SH FOX-1SHR**

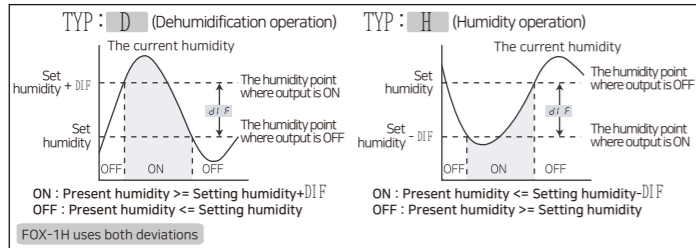

COR : The current humidity calibration **FOX-1H FOX-1SH FOX-1SHR**

- The function calibrates the current humidity to be consistent with the actual humidity if the humidity shown in the display window and the actual are humidity are different despite the product has no problem.

Ex) Actual Humidity : 55%RH, Current Humidity : Suppose the COR value is set -2 when 57%RH, the current humidity will be displayed at 55%RH.

Caution : The performance of the actual humidity is verified. Please use calibrated equipment for calculation. Calibration based on humidity calculation with incorrect equipment may cause product malfunction.

HEL : Humidity sensor heating function **FOX-1SH FOX-1SHR**

- It is possible to be covered with dew when the humidity is high, If the present humidity is 95%, it is generated heat under its sensor on order to prevention of dewy.

YES : The heating function operates automatically in 95% or more humidity and the function is disabled when humidity level is below 95%

NO : The automatic heating function is not used.

Caution : It must be set up "NO" because the heating function can not be used for more than 95%

Caution : The present temperature's display can be increased a little while operating as the humidity sensor's heating function.

ADR : RS485-communication address setting **FOX-1SHR**

- The product FOX-1SHR supports RS485 communications. when communicating with the master device for mutual recognition is the ability to set the communication address.

BAU : RS485-communication speed setting **FOX-1SHR**

- The product FOX-1SHR supports RS485 communications. when communicating with the master device for mutual recognition is the ability to set the communication speed.

08 Diemension and panel hole sizes

(Unit : mm / error : ±0.5)

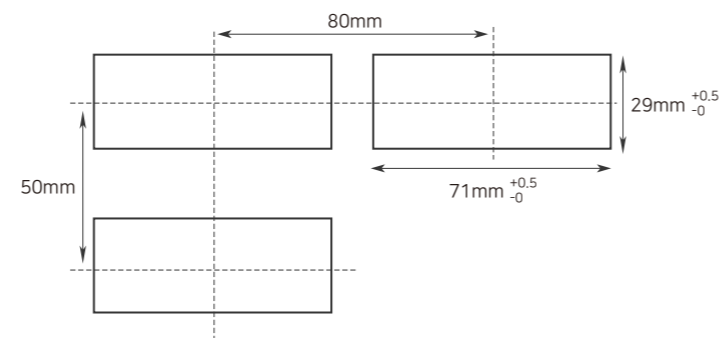
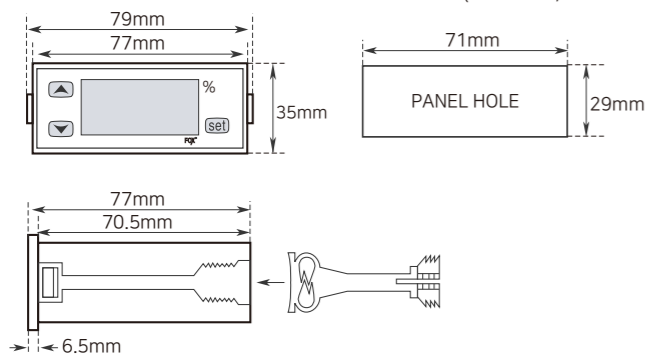

09 Sensor's specifications

[DS-SH Series]

FOX-1SH FOX-1SHR

Model classification: DS-SH **A H**

- A (Humidity Accuracy) H (Housing Type)
- 0 : ±4.5%
 - 1 : ±3.0%
 - 5 : ±2.0%
 - 04 : Stainless Body Length 40mm(Possible ambient temperature up to 80°C)
 - 12 : Stainless Body Length 120mm(Possible ambient temperature up to 80°C)
 - 220 : Plastic Case

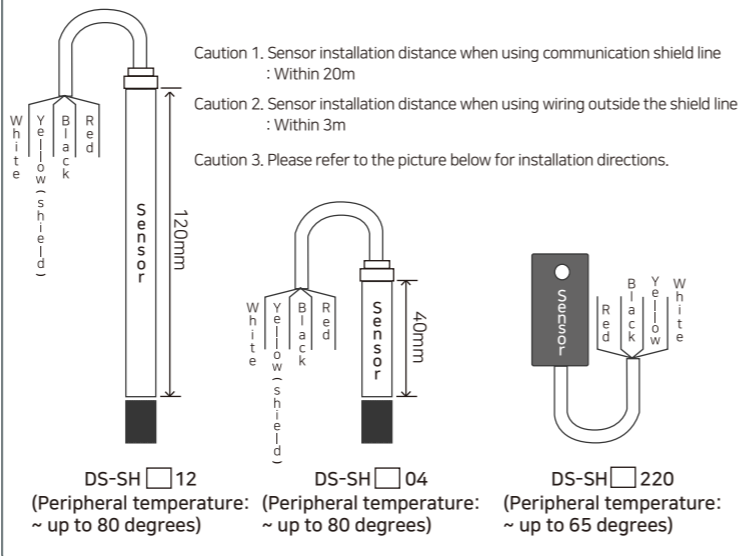

[HCPV-220H]

FOX-1H

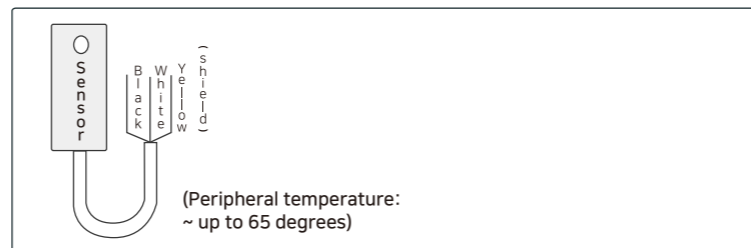

10 Communication interface (FOX - 1SHR)

Applicable specification	EIA RS485
Communications method	2-line half-duplex;Asynchronous
Synchronization method	Asynchronous system
Data speed	1200/2400/4800/9600/19200bps(5 options)
Communications range	Within 1.2Km
Communications protocol	BCC
Start Bit, Stop Bit	1Bit (fixed)
Parity Bit, Data Bit	Parity Bit : None, Data Bit : 8Bit (fixed)

[SYSTEM]

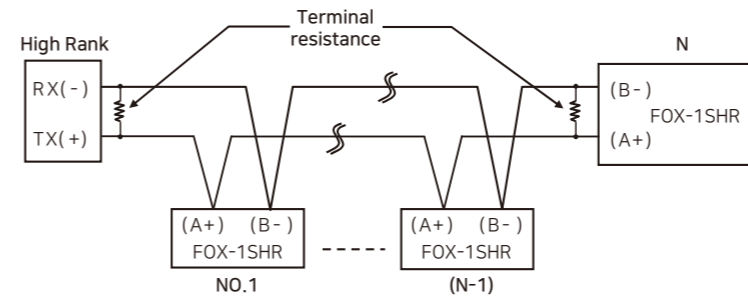

Definition between communication command and block

[Top (HOST) Query (Question) format]

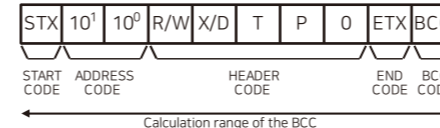

[FOX-1SHR Response (Reply) Format]

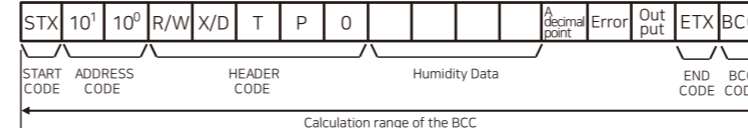

- START CODE**
Show the lead(head) of the block
STX→[02H]
- ADDRESS CODE**
A high rank system can discriminates the channel code number among 1SHR. It is available to set between 01~09(BCD ASCII)
- HEADER CODE: Show the command name as an alphabetic letter**
TPO(Temperature measurements) RX (Reading Demand) →R[52H],X[58H]
→T[54H],P[50H],O[30H]
RD (Reading Response) →R[52H],D[44H]
HP0(Humidity measurements) WX (Writing Demand) →W[57H],X[58H]
→H[48H],P[50H],O[30H]
WD (Writing Response) →W[57H],D[44H]
- Composition of DATA:** DATA is displayed as (Hexadecimal) (Negative: 2's remuneration)
- Decimal Point:** 0[30H]:There is no "Decimal Point"/1[31H]:There is "Decimal Point"
- Error:** 0[30H]:There is no 'error'/1[31H]:Interrupted of the sensor's cable
2[32H]:Low error//3[33H]:High error
- Output:** 0[30H]:output OFF//1[31H]:output ON
- END CODE:** Show the end(close)of the block. ETX→[03H]
- BCC:** (Block Check Character) Show the XOP arithmetic and logic values from the start (STX) to the ETX

etc

- As of no response of the ACK
 - In case of not equivalent to the channel after receiving STX
 - In case of generating the (Recevice Buffer Overflow)
 - In case of not equivalent to the communication's set values or baud rate
- In case of no response of the ACK
 - Check the cable
 - Check the communication's condition (set values)
 - If the main cause of the status is the noise, try to do communication practicing 3times until recovering nomally
 - Change the communication speed in case of bring about the communication's error frequently

11 Application for humidity controller

[A Dehumidifier → turn off at 43%RH,turn on at 47%RH
How to operate(setting for the humidity&programs) ?]

User's setting humidity changing : 43%RH Program setting TYP : D DIF : 4%Rh

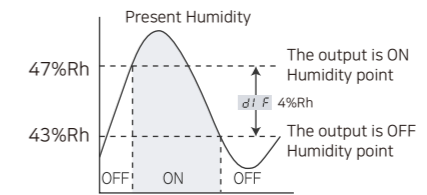

[A Humidifier → turn off at 43%RH,turn on at 40%RH
How to operate(setting for the humidity&programs) ?]

User's setting humidity changing : 43%RH Program setting TYP : H DIF : 3%Rh

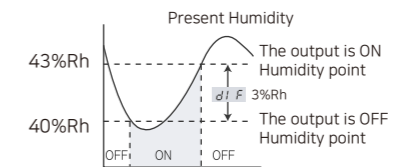

12 Easy error diagnosis instructions

※ If an error is displayed while the product is running

- ER1** : It is case where the product was subject to a strong external noise and internal data memories have been damaged In this case, contact us for product service.
- Although this controller was designed to withstand a certain level of external noise, it is not supposed to withstand all levels of noise.
- If the product is subject to a noise greater than 2KV, it could be internally damaged.
- OE** display means communication defect with the sensor. Please check connection, wire short, and connection order to the sensor. If the problem persists, please contact our customer. service department.
- LE** or **HE** is shown when humidity display has exceeded the range. If the error is displayed despite maintaining our customer service department

※ The above specifications may be changed without any notice for performance enhancement. Please make yourself fully familiar with and follow the above precautions.

■ Warranty period: One year from the date of purchase

■ Address : (Street address) 56, Ballyongsandan 1-rp, Jangan-eup, Gijang-gun, Busan, ROK
(Land-lot address) 901-1, Ballyong-ri, Jangan-eup, Gijang-gun, Busan, ROK (46034)

- Product service : 070-7815-8289
- Customer service : 051-819-0425 ~ 0427
- FAX : 051-819-4562
- Email : conotec@conotec.co.kr
- SNS : Facebook, Instagram, Twitter, YouTube ▶ 'Search for 'Conotec'
- Website : www.conotec.co.kr

Major products and development

- Temperature/humidity controller
- Counter and timer controller
- Current and voltage panel meter
- Temperature/humidity indicator
- Oven controller
- CO2 controller
- PID controller
- Unit cooler controller
- Heat pump controller
- Chiller controller
- Thermo-hygrostat controller
- Short message alarm
- Temperature/humidity transmitter
- Smartphone app and monitoring system

※ This manual was prepared in the Naver Nanum fonts.